

## FORGED FORK LINK CHAINS

## STANDARD SERIES

### Link Material Options

* Manganese Alloy Steel (18MnCr B5)
* Chrome-Nickel Alloy Steel (18NiCrMo5) Case Hardened (CN)
* Carbon Steel (C45) Hardened & Tempered (C)
* Chrome Molly Alloy Steel (42CrMo4) Hardened Tempered (CD)
* Stainless Steel AISI 304 (S3) AISI 420 (S4) AISI 316 (S5)

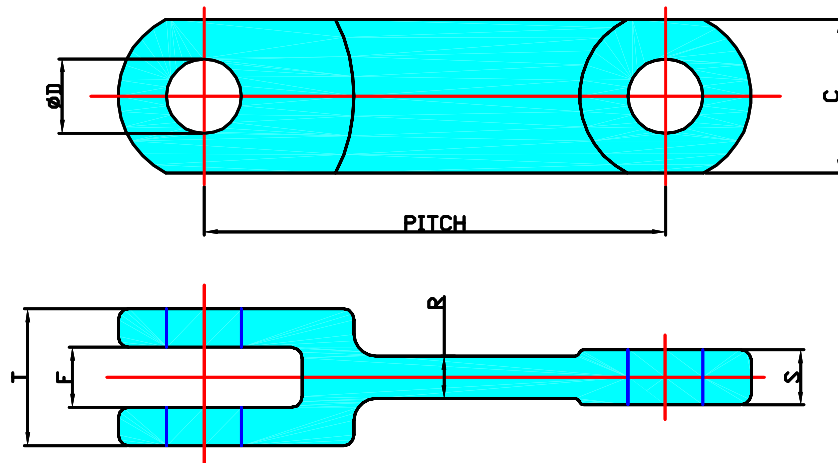

All measurements in mm. Ultimate strength KN

CHAIN N°	PITCH	T	C	S	F	R	φD
10160	101.6	24	36	8	10	6	14
10160/R	101.6	30	36	13	14	9	14
14218	142	42	50	19	20	11	25
14226	142	62	50	28	30	15	25
21640	216	64	72	26	28	20	35
26040	260	70	75	31	33	20	32

CHAIN N°	AVERAGE ULTIMATE STRENGTH			
	MN	CN	C	CD
10160	110	120	150	210
10160/R	180	195	235	330
14218	290	320	370	550
14226	440	470	570	790
21640	720	820	980	1200
26040	840	900	1100	1480



Forged Chain Specialist  
Paul Hale  
Tel/Fax: (44) 01453 549021  
Mobile: 07725 670141  
E-mail:  
hale@lindenlea60.freeserve.co.uk

(UK) John King Chains Limited.  
New Climax Works, Lancaster Way, Sherburn in Elmet LS25 6NS UK  
Telephone: (44) 01977 681910  
Facsimile: (44) 01977 681899  
E-mail: admin@johnking-chain.com  
technical@johnking-chain.com  
sales@johnking-chain.com

John King (USA) Inc.  
200 Catherine Street, Unit 7B, E. Peoria IL61611 USA  
Telephone: 309-698-9250  
Facsimile: 309-698-9259  
E-mail: salesusa@johnking-chain.com

Web: www.johnkingchains.com

FS1.1

## FORGED FORK LINK CHAINS

## DOUBLE SERIES

### Link Material Options

- \* Manganese Alloy Steel (18MnCr B5)
- \* Chrome-Nickel Alloy Steel (18NiCrMo5) Case Hardened (CN)
- \* Carbon Steel (C45) Hardened & Tempered (C)
- \* Chrome Molly Alloy Steel (42CrMo4) Hardened Tempered (CD)
- \* Stainless Steel  
 AISI 304 (S3)  
 AISI 420 (S4)  
 AISI 316 (S5)

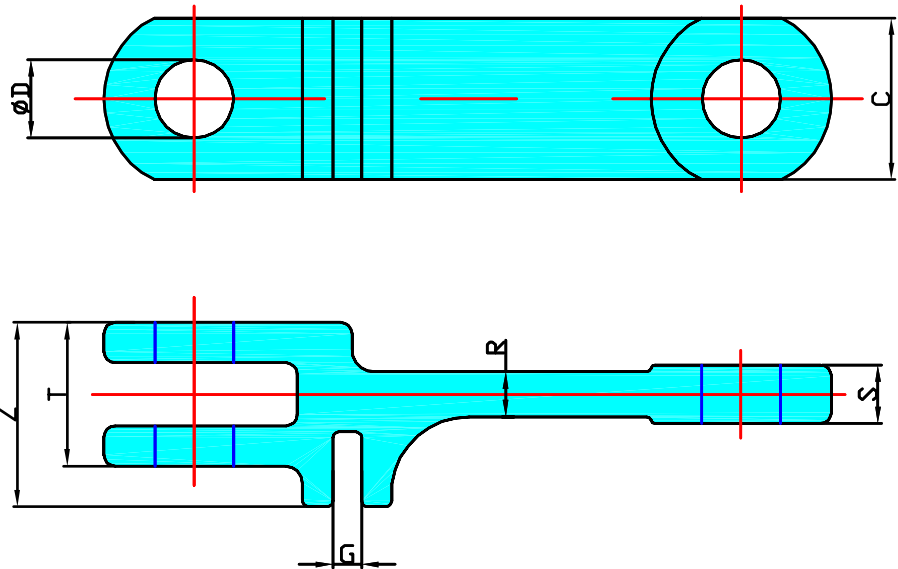

All measurements in mm. Ultimate strength KN

CHAIN N°	PITCH	T	Z	C	S	G	R	$\phi D$
142182	142	42	70	50	19	12	11	25
142262	142	62	87	50	28	12	15	25
175402	175	72	65	60	30	16	23	30
200252	200	60	81	50	25	12	18	25
250602	250	100	140	70	45	21	36	35

CHAIN N°	AVERAGE ULTIMATE STRENGTH			
	MN	CN	C	CD
142182	290	320	370	550
142262	440	470	570	790
175402	470	530	670	800
200252	320	360	460	540
250602	850	960	1180	1410



Forged Chain Specialist  
 Paul Hale  
 Tel/Fax: (44) 01453 549021  
 Mobile: 07725 670141  
 E-mail:  
 hale@lindenlea60.freeserve.co.uk

(UK) John King Chains Limited.  
 New Climax Works, Lancaster Way, Sherburn in Elmet LS25 6NS UK  
 Telephone: (44) 01977 681910  
 Facsimile: (44) 01977 681899  
 E-mail: admin@johnking-chain.com  
 technical@johnking-chain.com  
 sales@johnking-chain.com

John King (USA) Inc.  
 200 Catherine Street, Unit 7B, E. Peoria IL61611 USA  
 Telephone: 309-698-9250  
 Facsimile: 309-698-9259  
 E-mail: salesusa@johnking-chain.com

Web: www.johnkingchains.com

## FORGED FORK LINK CHAINS

### PIN CONFIGURATION

standard arrangement is for parallel pin with double circlip retention. Headed pins are generally employed on double strand conveyors to ensure maximum integrity if contact between pin head & conveyor casing occurs. Collar style is an option if material is of a particularly abrasive nature where retention needs to be more substantial than with standard circlips. For corrosive environments a snub pin with anti-rotation feature is the proven performer.

### SPECIFICATIONS

Standard pins are manufactured from NICK alloy steel case hardened to 54/58 Hrc case depths vary between 0.6 & 1.0mm dependent on diameter.

In environments where both corrosion & abrasion are experienced stainless steel Aisi 440 heatreated to 45 Hrc is selected. For optimum corrosion resistance austenitic stainless steel Aisi 304 or Aisi 316 are required.

### LINER BUSHES

Special specification pins are often used in conjunction with liner bushes pressed into the link pitch holes. materials are to an equivalent standard to chain pins.

Type W - Split bush for abrasion resistance  
Type C - Solid bush for corrosion resistance

## CHAIN PINS

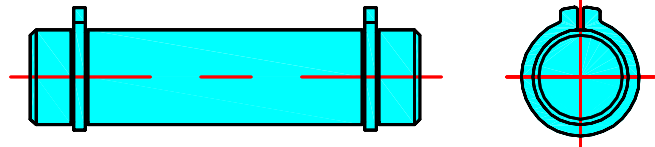

**PLAIN PIN AND TWO CIRCLIPS**

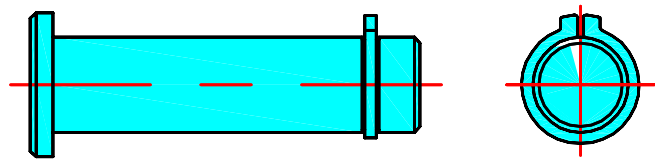

**HEADED PIN AND ONE CIRCLIP**

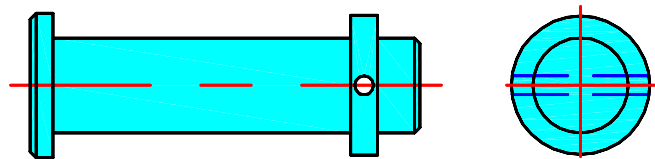

**HEADED PIN . COLLAR AND SPIROL PIN**

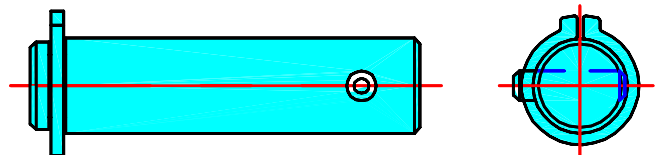

**SNUB PIN WITH ANTI ROTATION FEATURE**

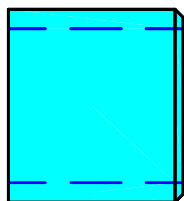

**LINEAR BUSH TYPE C**

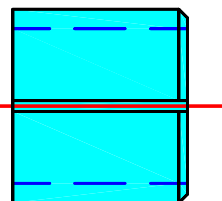
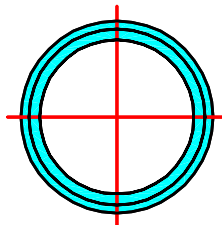

**LINEAR BUSH TYPE W**

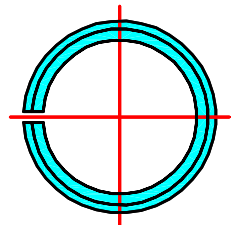

Forged Chain Specialist  
Paul Hale  
Tel/Fax: (44) 01453 549021  
Mobile: 07725 670141  
E-mail:  
hale@lindenlea60.freeserve.co.uk

(UK) John King Chains Limited.  
New Climax Works, Lancaster Way, Sherburn in Elmet LS25 6NS UK  
Telephone: (44) 01977 681910  
Facsimile: (44) 01977 681899  
E-mail: admin@johnking-chain.com  
technical@johnking-chain.com  
sales@johnking-chain.com

John King (USA) Inc.  
200 Catherine Street, Unit 7B, E. Peoria IL61611 USA  
Telephone: 309-698-9250  
Facsimile: 309-698-9259  
E-mail: salesusa@johnking-chain.com

Web: www.johnkingchains.com

FS1.3

## FORGED FORK LINK CHAINS

## TYPICAL FLIGHT ARRANGEMENTS

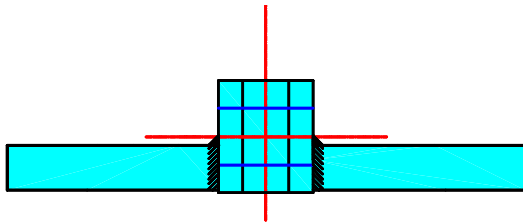

'T' BAR FLIGHT

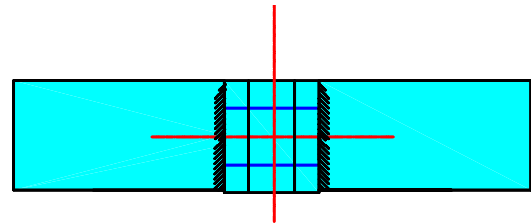

'BT' PLATE FLIGHT

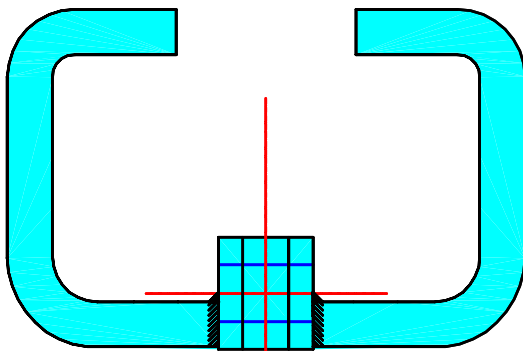

CLOSED 'C' FLIGHT

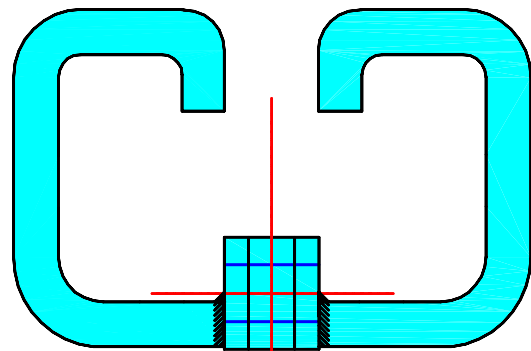

'00' FLIGHT

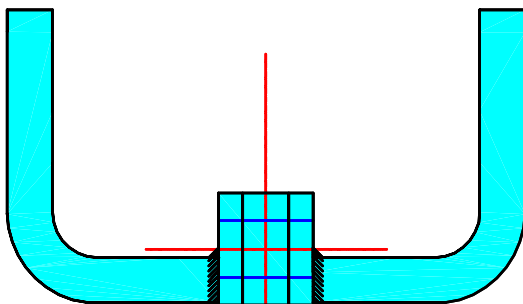

'U' FLIGHT

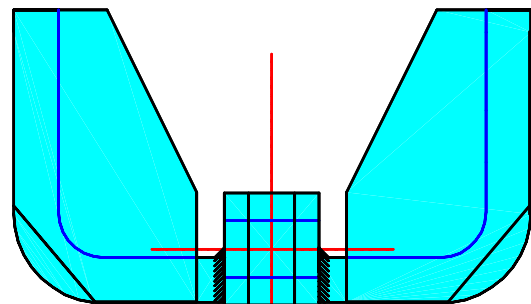

'U' FLIGHT WITH BLANKING PLATE

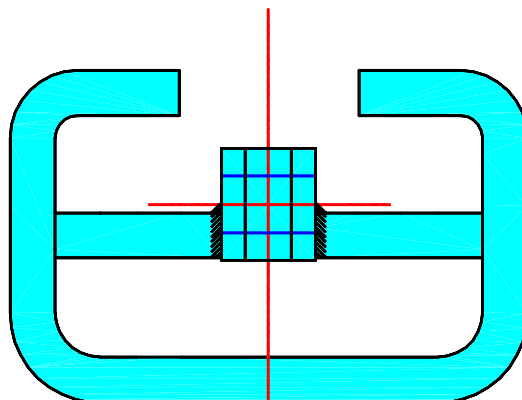

'H' FLIGHT



Forged Chain Specialist

Paul Hale

Tel/Fax: (44) 01453 549021

Mobile: 07725 670141

E-mail:

hale@lindenlea60.freeserve.co.uk

(UK) John King Chains Limited.

New Climax Works, Lancaster Way, Sherburn in Elmet LS25 6NS UK

Telephone: (44) 01977 681910

Facsimile: (44) 01977 681899

E-mail: admin@johnking-chain.com

technical@johnking-chain.com

sales@johnking-chain.com

John King (USA) Inc.

200 Catherine Street, Unit 7B, E. Peoria IL61611 USA

Telephone: 309-698-9250

Facsimile: 309-698-9259

E-mail: salesusa@johnking-chain.com

Web: www.johnkingchains.com

FS1.4

## FORGED FORK LINK CHAINS

## ATTACHMENT

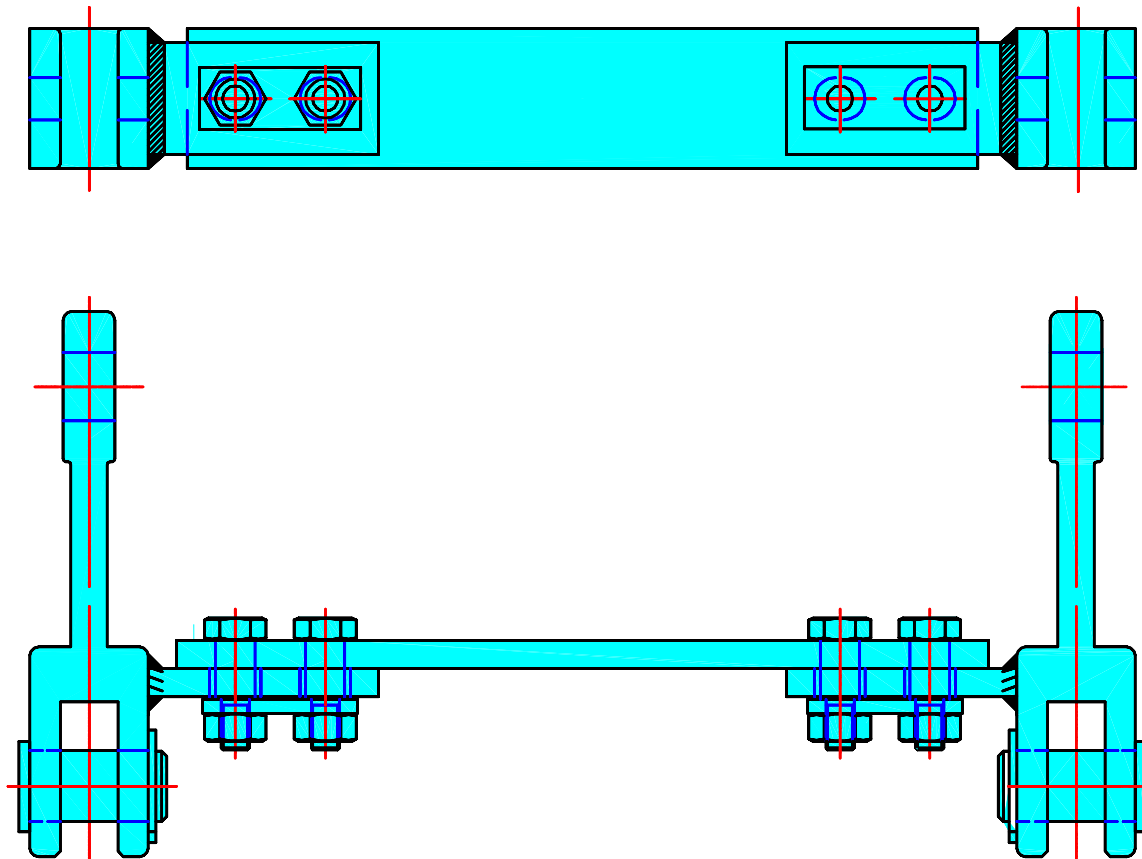

*FORGED LINK ATTACHMENT TO SUIT ALL DIFFERENT TYPES OF FORGED LINK.*

*10160, 10212, 14218, 14226, 16018 LINKS*



Forged Chain Specialist

Paul Hale

Tel/Fax: (44) 01453 549021

Mobile: 07725 670141

E-mail:

hale@lindenlea60.freeserve.co.uk

(UK) John King Chains Limited.

New Climax Works, Lancaster Way, Sherburn in Elmet LS25 6NS UK

Telephone: (44) 01977 681910

Facsimile: (44) 01977 681899

E-mail: admin@johnking-chain.com

technical@johnking-chain.com

sales@johnking-chain.com

John King (USA) Inc.

200 Catherine Street, Unit 7B, E. Peoria IL61611 USA

Telephone: 309-698-9250

Facsimile: 309-698-9259

E-mail: salesusa@johnking-chain.com

Web: www.johnkingchains.com

## FORGED FORK LINK CHAINS

## SPROCKETS

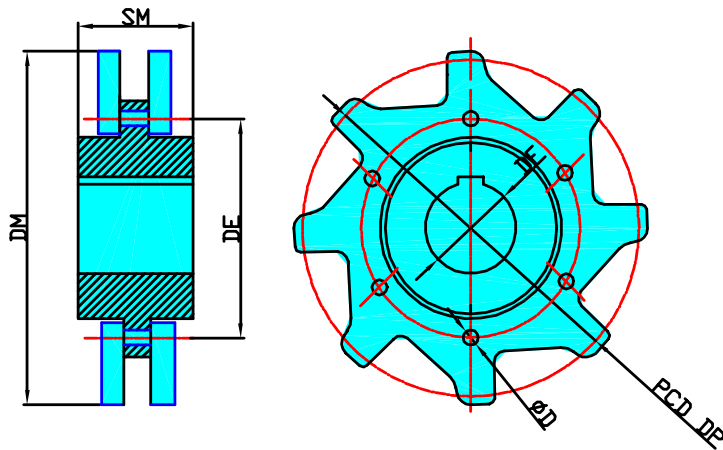

**STANDARD ASYMMETRICAL PATTERN**

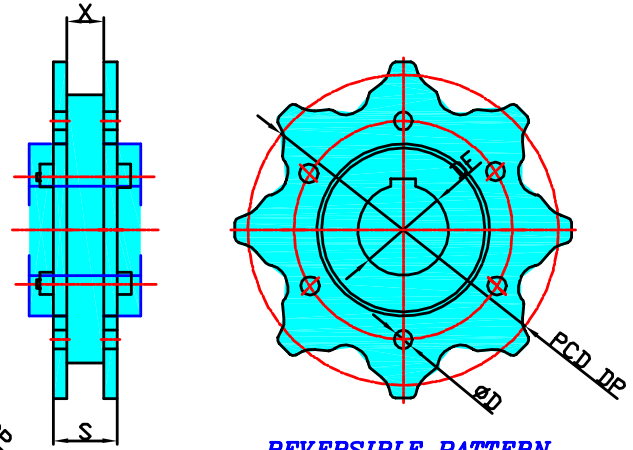

**REVERSIBLE PATTERN**

All measurements in mm.

CHAIN No.	No. OF TEETH	DM (TOP)	DP PCD	DE (HOLE PCD)	DF (MAX)	øD	No. OF HOLES	S	X	SM		
10160 10160R*	6	216	203.2	132	70	10	6	34	36*	10	12*	83
	7	246	235.1	146	70	12	6	34	36*	10	12*	83
	8	277	265.49	168	85	12	6	34	36*	10	12*	83
	10	340	328.78	200	105	12	6	34	36*	10	12*	83
	12	404	392.55	260	105	12	8	34	36*	10	12*	83
14218	6	304	284.0	168	85	12	6	45		15		95
	7	344	327.3	200	105	16	6	45		15		112
	8	390	371.06	241	115	20	8	45		15		127
	9	435	415.18	286	150	20	8	45		15		127
	10	480	459.52	286	150	20	8	45		15		127
	11	524	504.02	368	170	20	8	45		15		150
	12	570	548.64	415	170	20	8	45		15		150
	13	614	593.37	470	170	20	8	45		15		150
14	660	638.15	470	170	20	8	45		15		150	
14226	7	344	327.3	200	105	16	6	60		20		112
	8	390	371.06	241	114	20	8	60		20		150
	9	435	415.18	286	150	20	8	60		20		150
	10	480	459.52	286	150	20	8	60		20		150
	11	524	504.02	368	170	20	8	60		20		150
	12	570	548.64	415	170	20	8	60		20		150
	13	614	593.37	470	170	20	8	60		20		180
	14	660	638.15	470	170	20	8	60		20		180
21640	6	459	432.0	247.7	140	20	6	65		25		150
	7	524.8	497.8	311.2	140	24	8	65		25		150
	8	591.4	564.4	381.0	170	20	8	65		25		150
	9	658.5	631.5	431.8	170	24	8	65		25		203
	10	726	699.0	490.0	170	24	8	65		25		203
26040	8	710	679.40	460	180	20	8	82		25		150
	10	870	841.37	460	180	24	8	82		25		150
	12	1035	1004.56	460	180	24	8	82		25		150



Forged Chain Specialist  
 Paul Hale  
 Tel/Fax: (44) 01453 549021  
 Mobile: 07725 670141  
 E-mail:  
 hale@lindenlea60.freeserve.co.uk

(UK) John King Chains Limited.  
 New Climax Works, Lancaster Way, Sherburn in Elmet LS25 6NS UK  
 Telephone: (44) 01977 681910  
 Facsimile: (44) 01977 681899  
 E-mail: admin@johnking-chain.com  
 technical@johnking-chain.com  
 sales@johnking-chain.com

John King (USA) Inc.  
 200 Catherine Street, Unit 7B, E. Peoria IL61611 USA  
 Telephone: 309-698-9250  
 Facsimile: 309-698-9259  
 E-mail: salesusa@johnking-chain.com

Web: www.johnkingchains.com